

- 12 ottagonale**
Una cornice per l'arte nell'East End
Showcasing art in the East End *Andrea Mattiello*
- 29 editorialeditorial**
Memorie urbane
Urban memories *Aldo Colonetti*

LINK

- focus on**
- 70 Comunicare dinamismo e tecnologia**
Dynamic power and technology *Alessandra Bergamini*
- 78 Circuiti virtuosi per il tempo libero**
On the right track for leisure activities *Erica Marson*
- 84 A volte ritornano**
Back to the future *Giorgio Coppin*

reportage

- 90 Luce per indicare la via**
Light shows the way *Valentina Croci*

design encyclopaedia

- 98 Un catalogo di oggetti 'perfetti'**
A catalogue of perfect objects *Elena Brigi*

exhibition

- 102 Profezie genetiche**
Genetic prophecies *Elena Franzoia*

ABITARELIVING

interniinteriors

- 108 Ecologici e a basso consumo energetico**
Eco-friendly and energy saving *Er. M.*
- 114 Dis-ordinare lo spazio**
Dis-ordering space *E. F.*
- 120 Chiostri di luce aperti sul Danubio**
Cloisters of light open onto the Danube *Elena Vai*
- 124 Prospettiva interiore**
Interior perspective *E. V.*

rivestimenticeramics

- 130 Ceramica ad alta sostenibilità ambientale**
High-sustainability ceramics *Santino Limonta*

kitchen

- 138 Composizioni e geometrie la ricerca dell'essenziale**
Layouts and geometries: the recipe for essentiality *Silvia Airolidi*

caloreheat

- 142 Il caldo pulito**
Clean heat *Vittoria Morganti*

hi-tech

- 146 Figli del design strategico**
The offspring of strategic design *Alessandra Ritondo*

prodottiproducts

- 152 Una stanza tutta per sé**
A room of one's own *Daniela Patanè*

ARCHITETTURA

Cover city

- 164 San Paolo identità senza confini**
São Paulo: unlimited identities *Sebastiano Brandolini, Domenico Conaci*

Cover city design

- 196 L'industria della creatività**
The industry of creativity *V. C.*



34



46

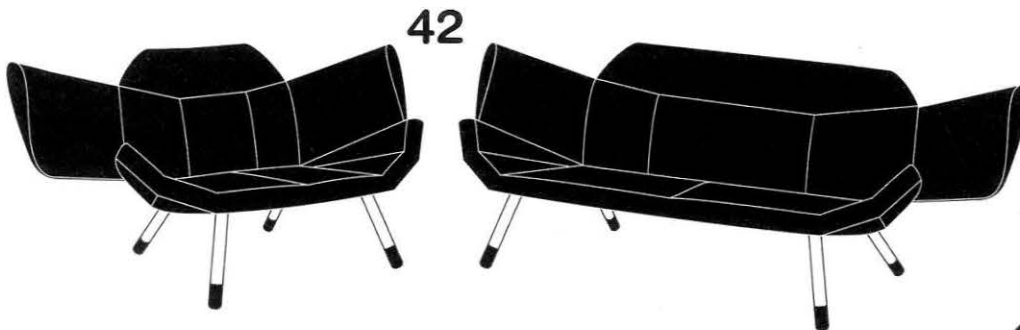

42

44



RUBRICHEREGULARS

20 **flash** a cura di/edited by Vega Partesotti

30 **lettereletters**

mostreexhibitions

32 **Orizzonti lontani**
Distant horizons V. P.

34 **Westwood tra provocazione e filologia**
Westwood, creativity and scientific precision V. P.

calendario eventievents calendar
36 **Gli eventi di dicembre/gennaio**
December/January events

libribooks

38 **Reinterpretare la tradizione**
Reinterpreting tradition V. P.

40 **Mappatura del progetto**
Mapping design E. V.

concorsocompetitions

42 **Il trionfo della linearità**
Linearity triumphs D. P.

new designer

44 **Idee che vengono da lontano**
Ideas from afar D. P.

new materials

46 **Cocco, un frutto esotico da interni**
Coconut: an exotic fruit for interiors Alessandro Lolli

superficiesurfaces

48 **Miscelando materiali e ironia**
Witty materials Alessandro Lolli

fashion

52 **Greenstorming** Marta Buscaroli

orologiwatches

54 **Ceramica da polso in serie limitata**
Limited-edition ceramics for the wrist Alberto Uglietti

location

56 **Camera con vista... su Parigi**
Room with a view ... of Paris V. P.

cantiere

58 **Cantiere di Lavoro. Città, Mobilità, Cultura**
Worksites: City, Mobility, Culture Er. M.

eventievents

60 **Base2, al centro del talento**
Base2, at the centre of talent S. A.

62 **Firenze laboratorio di idee**
Florence, workshop of ideas Silvia Tugnoli

64 **Premiare la pietra**
Awarding stone Er. M.

meteodesign

66 a cura di/edited by Tommaso Maggio

204 **flash architettura**

a cura di/edited by Alessandra Bergamini

city

206 **Finestra sul lago**
A window onto the lake A. B.

landscape

208 **Disegnare la natura**
Lighting paints nature A. B.

concorsi architettura
architecture competitions

210 **Edifici come mezzi di comunicazione**
Buildings as channels of communication D. P.

restaurorestoration

212 **Invito alla corte reale**
Invitation to the royal court Valentina Croci

report fierefairs report

216 a cura di/edited by S. L.

fierefairs

228 **Imm Cologne punta ancora sul design**
IMM Cologne once again looks to design S. L.

230 **A Parigi debutta Maison&Objet Musées**
Paris hosts the debut of Maison&Objet Musées S. L.

calendario fierefairs calendar
231 **Gli appuntamenti di dicembre/gennaio**
The not-to-be missed events of December/January

236 **indirizzi**

236 **showroom shot**

236 **bookshop**

COMPANY PROMO

232 **IVM**

234 **LineaLight**

copertinacover



In copertina/cover: vista di San Paolo/View of São Paulo. Photo Eduardo Barillari.